

MX23FB VE01
220-240V 50Hz ~1

COMPRESSOR

Displacement (cm ³)	23.2
Diameter (mm)	34.93
Stroke (mm)	24.2
Net Weight (Kg)	17.5
Oil type	ISO VG 46 ESTER
Oil charge (cm ³)	650

MOTOR

Approximate Power (CV)	7/8
Voltage/Frequency (V/Hz)	220V 50Hz
Voltage range (V)	187-264
Code	82.199
Type	CSR
Phase number	1 PH
Locked rotor current (A)	24.0
Main W. resist. at 25°C (Ω)	2.65
Start W. resist. at 25°C (Ω)	7.24

APPLICATION

Application	Low back pressure
Refrigerant	R404A
Evaporating (°C)	-40 to -10
Expansion	Capillar/Valve
Comp. cooling	Fan cooled
Max. ambient temp. (°C)	43

NOMINAL PERFORMANCE

	CYCLE A	CYCLE B
Cooling capacity (kcal/h)	620	915
Input power (W)	751	790
EER (kcal/Wh)	0.82	1.15
COP (W/W)	0.95	1.34
Current (A)	3.80	3.99

TEST CONDITIONS

	CYCLE A	CYCLE B
Evaporating temp. (°C)	-25.0	-23.3
Condensing temp. (°C)	55.0	55.0
Liq.t. entering expan. (°C)	55.0	32.0
Ambient t. and return (°C)	32.0	32.0
Tens/Freq (V/Hz)	220V 50Hz	220V 50Hz

ELECTRICAL COMPONENTS

Relay	3ARR3 10AA3	RVA 4M..
Pick-Up (A)	239-270	242-270
Drop-Out (A)	50-110	50-110
Protector	MRA38128	T0535/G..
Current (A)	17.0	17.0
Time check (seq)	7.5-14	7.5-14
Disc temp. (Open/Close) (°C)	105.0 / 52.0	105.0 / 52.0
Starting capacitor (μF/V/FV)	72- 88 / 330	
Run capacitor (μF/V)	16 / 400	

DIMENSIONS AND ELECTRICAL DIAGRAM

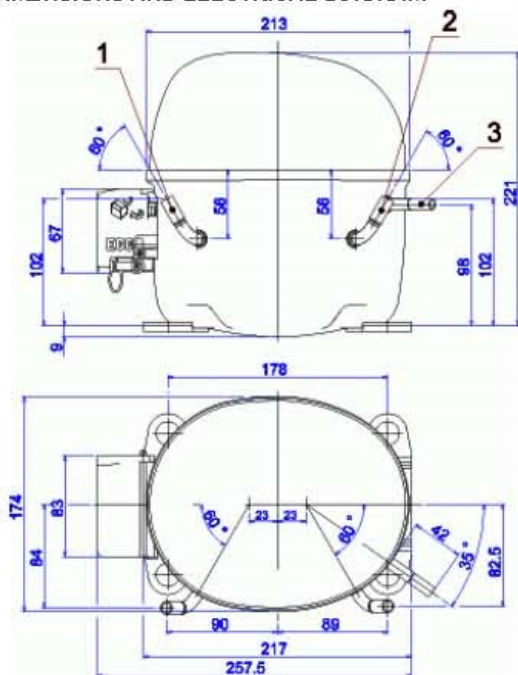

	DESIGNATION	INTERNAL DIAM. (MM)
1	Service	9.7
2	Suction	9.7
3	Discharge	6.5

CSR

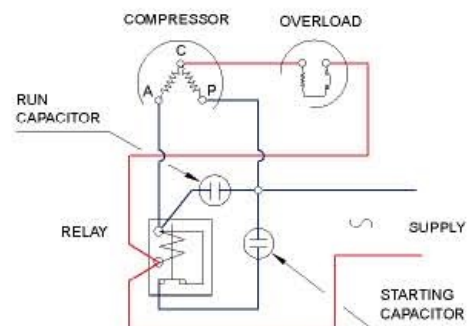

TEST CONDITIONS

Voltage/frequency	220V 50Hz
Ambient t. and return	32 °C
Liq.t. entering expan.	Subcooling at 32 °C

MASS FLOW

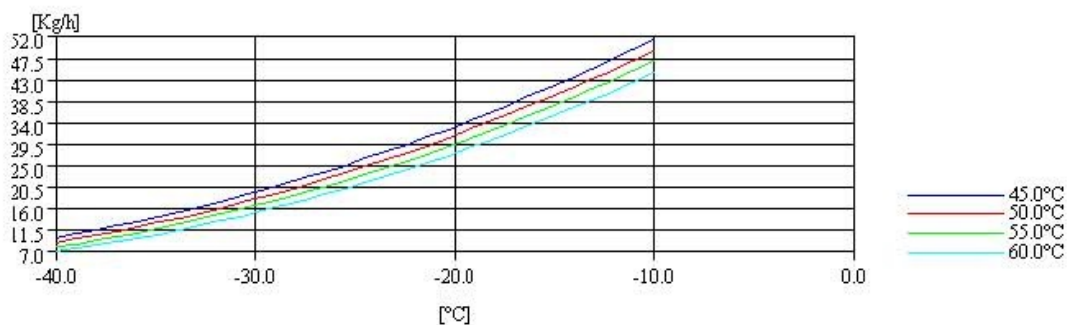

INTENSITY

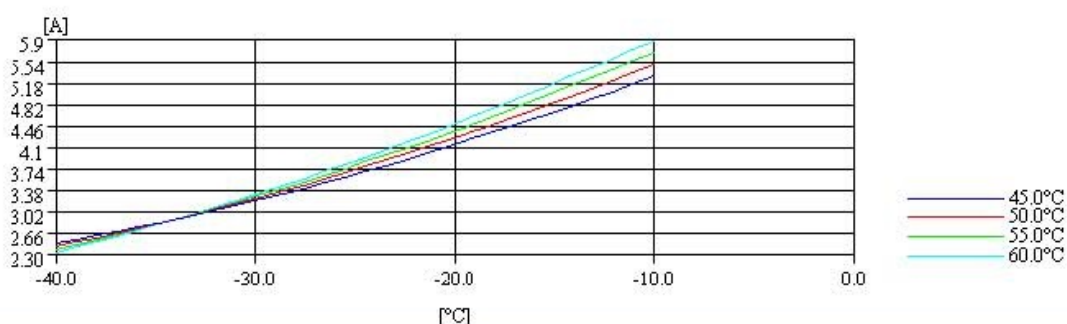

CONSUMPTION

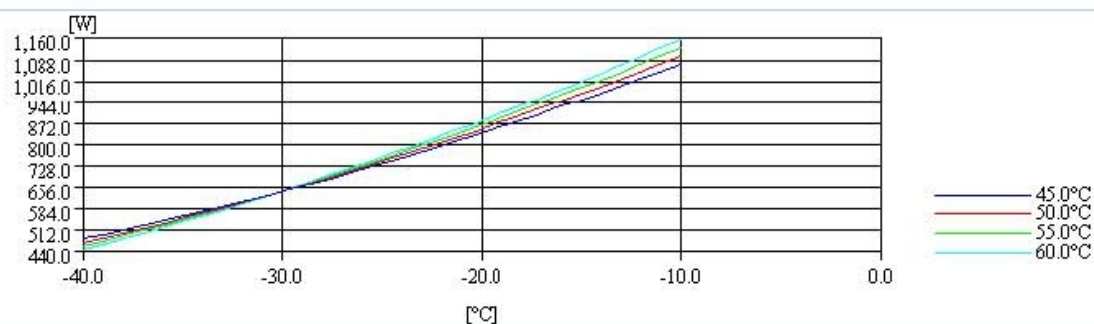

COOLING CAPACITY

