

**COMPRESSOR**

Displacement (cm <sup>3</sup> )	14
Diameter (mm)	31.19
Stroke (mm)	18.54
Net Weight (Kg)	11.5
Oil type	ISO VG 22 ESTER
Oil charge (cm <sup>3</sup> )	400

**MOTOR**

Approximate Power (CV)	3/8
Voltage/Frequency (V/Hz)	220V 50Hz
Voltage range (V)	198-264
Code	61,502
Type	CSIR
Phase number	1 PH
Locked rotor current (A)	18.0
Main W. resist. at 25°C (Ω)	4.79
Start W. resist. at 25°C (Ω)	23.96

**APPLICATION**

Application	High/Mid. back pressure
Refrigerant	R134a
Evaporating (°C)	-25 to 10
Expansion	Capillar/Valve
Comp. cooling	Fan cooled
Max. ambient temp. (°C)	43

NOMINAL PERFORMANCE	CYCLE C	CYCLE D
Cooling capacity (W)	999	1198
Input power (W)	565	590
EER (kcal/Wh)	1.52	1.74
COP (W/W)	1.76	2.03
Current (A)	3.27	3.39

**TEST CONDITIONS**

Evaporating temp. (°C)	5.0	7.2
Condensing temp. (°C)	55.0	55.0
Liq.t. entering expan. (°C)	55.0	46.0
Ambient t. and return (°C)	32.0	35.0
Tens/Freq (V/Hz)	220V 50Hz	220V 50Hz

**ELECTRICAL COMPONENTS**

Relay	9660 A 149	MTRP 48
Pick-Up (A)	7,70	7,80
Drop-Out (A)	6,50	6,65
Protector	MRP00AMK	T0425
Current (A)	11.7	11.5
Time check (seg)	7.5-14	7.5-14
Disc temp. (Open/Close) (°C)	105.0 / 61.0	105.0 / 61.0
Starting capacitor (μF/V)/F/V)	47- 56 / 330	

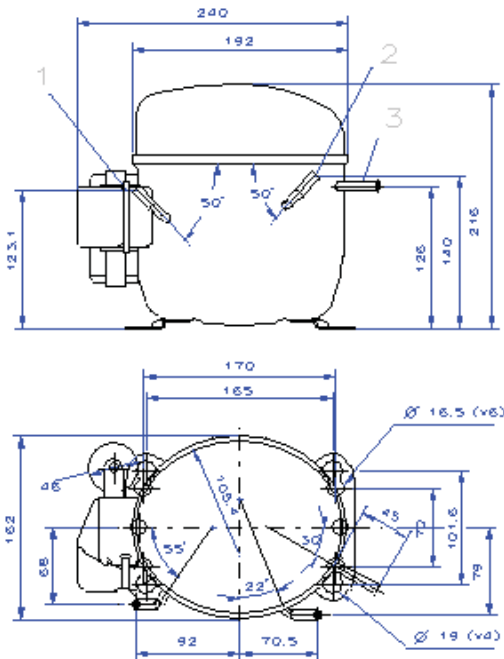
**DIMENSIONS AND ELECTRICAL DIAGRAM**

DESIGNATION	INTERNAL DIAM. (MM)
1 Suction/Service	8,1
2 Service/Suction	8,1
3 Discharge	6,5

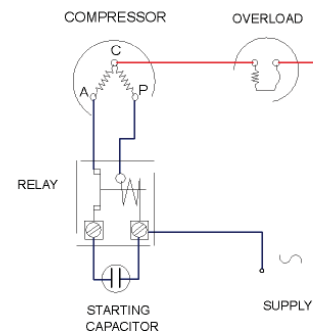
**CSIR**

**TEST CONDITIONS**

Voltage/frequency	220V 50Hz
Ambient t. and return	35 °C
Liq.t. entering expan.	Subcooling 9 K

**MASS FLOW**

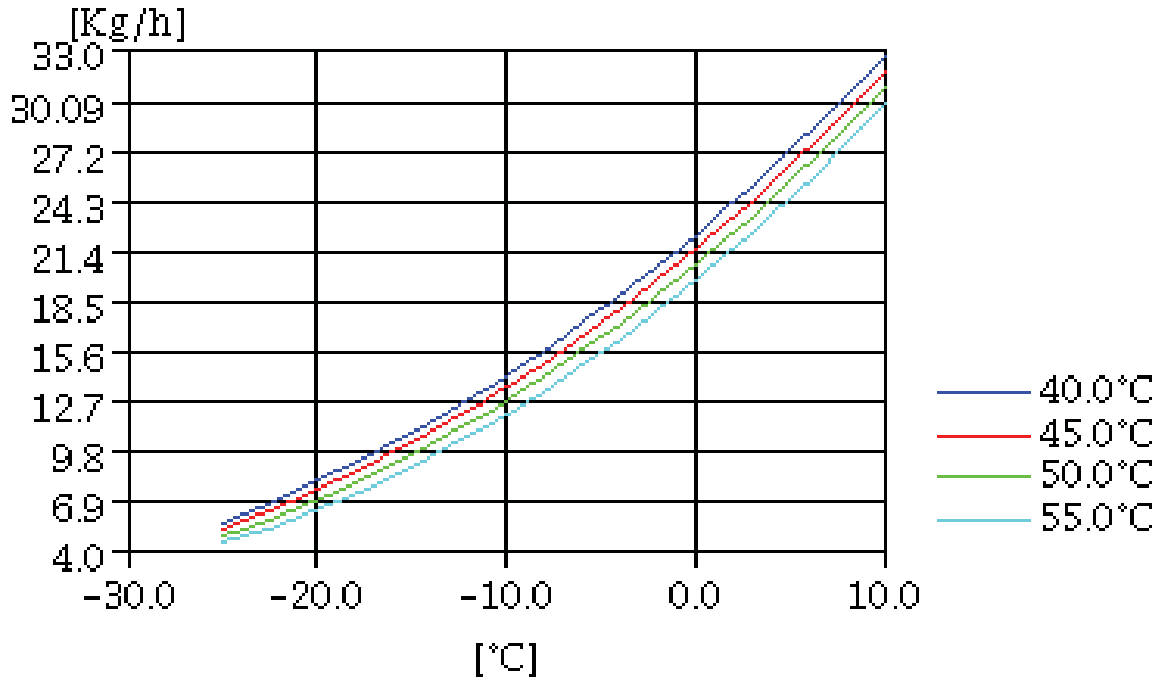

**CONSUMPTION**

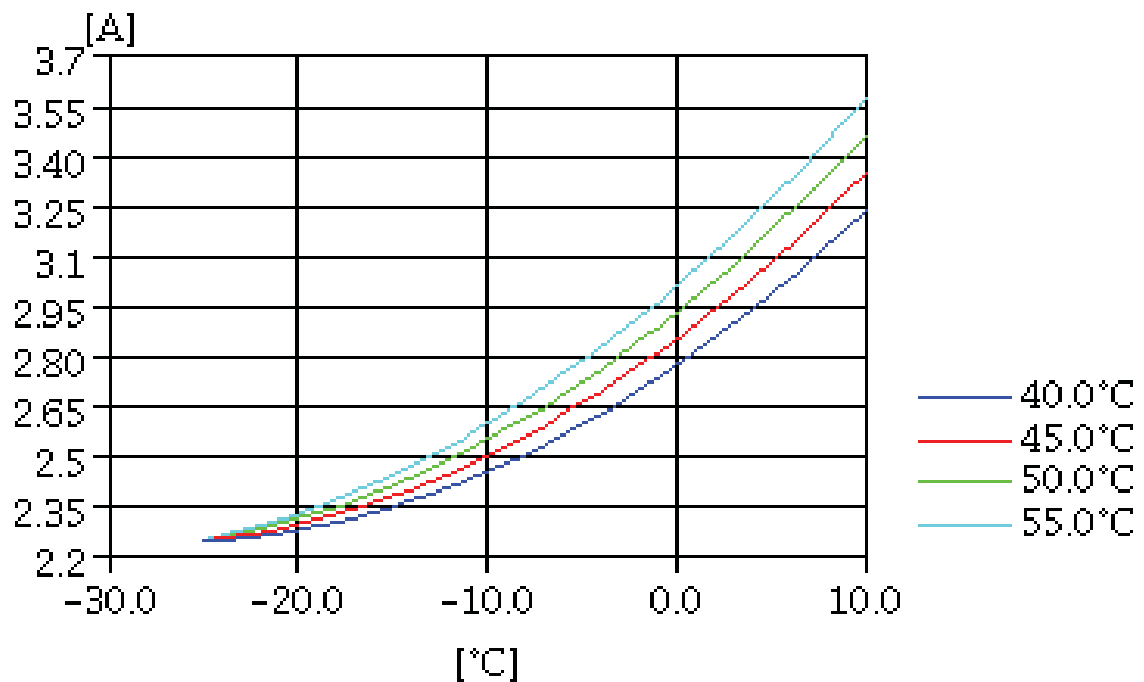

**TEST CONDITIONS**

Voltage/frequency	220V 50Hz
Ambient t. and return	35 °C
Liq.t. entering expan.	Subcooling 9 K

INPUT W

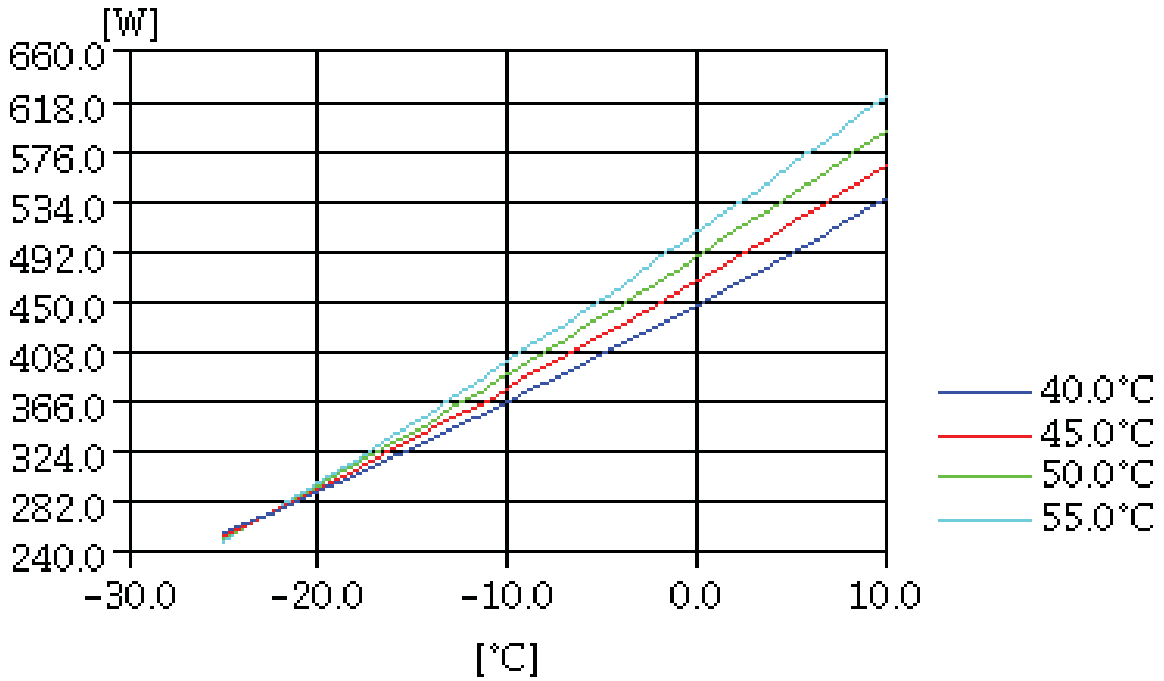

COOLING CAPACITY

